



**MASTERCHEM**

**PACKAGE  
INTEGRITY  
TESTER**



[www.mch.com.pl](http://www.mch.com.pl)

# PACKAGE INTEGRITY TESTER

■ Package integrity tester is a device for leak testing of packaging for liquid and semi-liquid cosmetic products, pharmaceutical and other industry packaging. It was designed and manufactured based on the experience of the greatest Polish packaging manufacturer with a European range – Masterchem Logoplaste.

■ The device may be used during current packaging production as well as in quality control departments. Our engineers took care not only of the solid and reliable construction, innovative lid opening system by means of servo-motor, but they also provided a device that uses compressed air only to operate.



## Features

- Economical and easy to use
- Ideal for leak testing of both flexible and rigid packaging intended for food, pharmaceuticals, industrial packaging and other
- Short testing sequence - maximum testing time up to 999 seconds
- Simple installation and start-up
- Low maintenance costs
- Easy to clean
- Intuitive to use

**ADJUSTABLE WORKING TIME** – timer may be set from 001 to 999 seconds, vacuum generation is initiated by pressing the button on the timer

**CHAMBER DOES NOT REQUIRE ELECTRICAL CONNECTION** - all you need to do is connect the source of compressed air

**DURABLE, ROBUST CONSTRUCTION** - test chamber provides tilting cover made of transparent material to enable inspection of workspace



# PACKAGE INTEGRITY TESTER

■ OPEN DEVICE

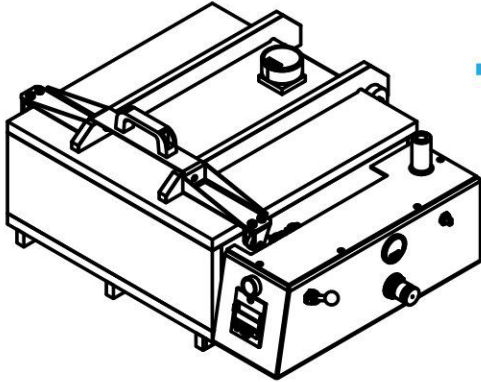

■ CLOSED DEVICE

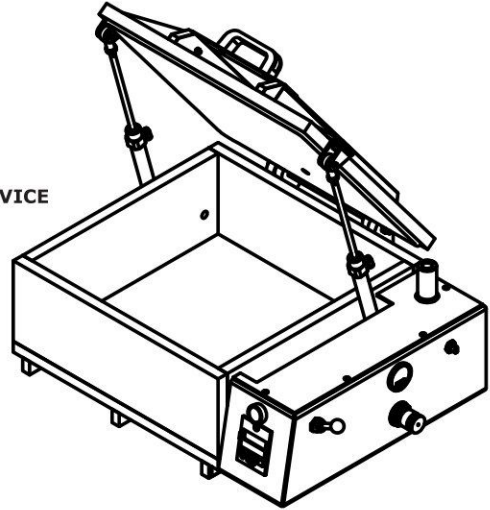

## Technical Specification

Parameter	Unit	Package integrity tester
Filtered oiled or non-oiled compressed air	bar	3,5 - 6
Chamber dimensions (L/W/H)	mm	650x500x300
Inner chamber dimensions	mm	400x400x150
Chamber weight	kg	23
Pressure reach time	bar / sec.	-0,6 / 60
Maximum testing time	sec.	999
■ Equipped with a terminal for vacuum gauge	-	YES

■ OPEN AND CLOSED DEVICE DRAWING

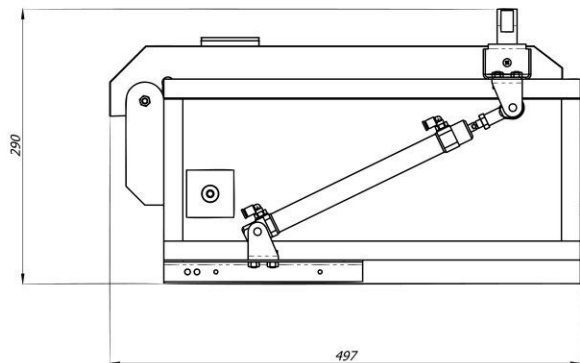
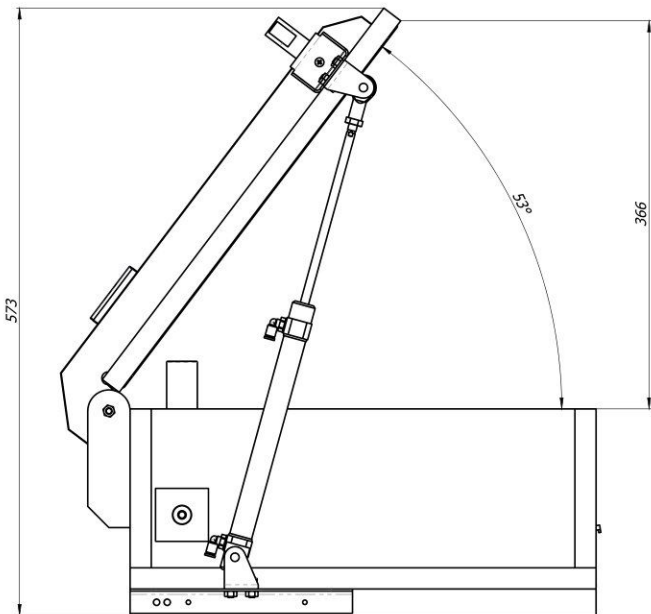

**MANUFACTURER OF PACKAGING, PET PREFORMS  
AND LIDS SUPPORTED BY OWN TOOLROOM  
SPECIALIZED IN MANUFACTURING OF FORMS  
AND PACKING MACHINES**



## **MASTERCHEM**

PHARMACY



COSMETICS



HOUSEHOLD  
CHEMICALS



ALCOHOL



FOOD  
PRODUCTS



PREFORMS



LIDS



**MASTERCHEM**

**Masterchem Logoplaste Sp. z o.o.**  
Poland, ul. Przylep - Solidarności 86d  
66-015 Zielona Góra, Poland

+48 68 324 08 56  
info@mch.com.pl  
www.mch.com.pl

Grupa  Logoplaste

